

# DIAGRAM UNIQUENESS OF EVEN PLATS

YOAV MORIAH AND JESSICA S. PURCELL

ABSTRACT. Every knot has a plat projection, obtained by closing up a braid with bridges. The plat projection is determined by the number of strands and the number of rows of twist regions in the braid, and an integer number of crossings in each twist region. In recent work, we showed that under certain restrictions, including that the number of rows is odd, a minimal width plat projection is unique. In this paper we extend the results to even plats. Using new arguments, we show that if each of their twist regions contains at least three crossings, and their length is sufficiently long with respect to their width, then the projection is unique. This essentially “doubles” the set of knots for which such diagrams classify the links.

## 1. INTRODUCTION

This paper provides further evidence that bridge number and plat diagrams give a better way to enumerate knots than crossing number. Since Tait began his knot tables in the late 1800s, knot theorists have been enumerating knots by crossing number. Such an enumeration leads to exponential growth of the number of knots, and no natural organization of diagrams. Further, it is difficult to determine when a link with an  $n$  crossing diagram is prime, or when it can be reduced. Consequently, in 150 years only diagrams with at most 17 crossings have been completely classified, and only up to mirror image. Moreover, very little can be deduced about the topology or geometry of a knot exterior from the fact that it has a given crossing number.

In the 1950s, moving away from crossing number, Schubert completely classified an *infinite* family of knots and links with fixed bridge number, namely the 2-bridge knots (also known as 4-plats) [11]. The 2-bridge links continue to serve as an infinite family for which further algebraic and geometric information can be read from a diagram. This paper adds to Schubert’s work and provides more evidence that bridge number can be used successfully to enumerate and classify knots and links.

Every knot and link has a *plat diagram*, for example as in Figure 1. The diagram has some number  $m$  of bridges, some number  $r$  of rows of twist regions, and for each twist region, an integral number of crossings. If we enumerate knots and links by this data, then every link will appear in the enumeration. However, there is still the question of uniqueness: when has a plat diagram already appeared in our list? In recent work [10], the authors showed that if  $m \geq 3$ , if there are at least  $c \geq 3$  crossings per twist region, if the number of rows  $r$  is odd, and if  $n = r + 1$  satisfies  $n > 4m(m - 2)$ , then the

---

*Date:* February 28, 2018.

*2010 Mathematics Subject Classification.* Primary 57M.

*Key words and phrases.* knot diagrams, plats, twist regions, vertical spheres, canonical projections.

Thanks to the Australian Research Council.

plat diagram is unique. There it was conjectured that a similar result held without the restriction to  $r$ . The reason that proof for  $r$  odd does not extend to  $r$  even is that it uses a crucial way the fact that *vertical surfaces* (see Definition 2.9 below) are incompressible and boundary incompressible. This is not true for even  $r$ .

In this paper we prove that conjecture, allowing even  $r$ , using a new method of proof. This essentially “doubles” the infinite class of knots and links that can be represented by unique diagrams. The precise statement is the following:

**Theorem 1.1** (Uniqueness of Diagrams). *Let  $\mathcal{K} \subset S^3$  be a knot or link with an even plat projection  $K'$  with  $m'$  bridges, where  $m' \geq 4$  and  $n'$ , the length of  $K'$ , satisfies  $n'$  is odd and  $n' > 4m'(m' - 2)$ . Suppose also that each twist region of  $K'$  contains at least three crossings. Finally, suppose that  $K$  is another plat or even plat projection of  $\mathcal{K}$  with  $m$  bridges. Then  $m \geq m'$ , and if  $m = m'$  and each twist region of  $K$  has at least one crossing, then  $K = K'$  up to rotation in a vertical axis.*

Thus if we enumerate knots and links by plat diagram, then although we are dealing with countable sets, we can make mathematically precise the statement that generically, a plat diagram will be unique. Moreover, deciding whether two such links are the same simply requires looking at the diagrams, a very easy task indeed. Finally, diagrams satisfying the conditions of Theorem 1.1 have many useful algebraic and geometric properties. The fundamental group, bridge number and tunnel numbers can be read off the diagram [9, 7]. The complement will be hyperbolic, and hence the link is prime [1]. If the number of crossings per twist region is increased to seven, there will be bounds on volumes [5] and exceptional Dehn fillings [6]. None of these properties hold for all diagrams with a given crossing number.

Knots in  $S^3$  which have a knot diagram that satisfies the conditions of Theorem 1.1 of [10] or Theorem 1.1 above will be call *rigid knots*. In light of the above the following questions become relevant:

**Question 1.2.** Given a knot  $\mathcal{K} \subset S^3$  is there an “effective” algorithm to decide if the knot is a rigid knot?

**Question 1.3.** Assume it is known that  $\mathcal{K} \subset S^3$  is a rigid knot. Is there an “effective” algorithm to decide what is the corresponding unique  $2m$  plat?

**Question 1.4.** Consider 3-manifolds obtained by surgery on knots that have a  $2m$  plat projection or a  $2m$  e-plat projection. Are there any topological differences between the two types of manifolds?

Finally, the results of [10] were obtained by investigating essential surfaces in plat diagrams as in [4, 3]. The existence of such surfaces was extended by Wu [13] to broader classes of plat diagrams. We propose the following conjecture, which would extend our results to Wu’s broader classes:

**Conjecture 1.5.** *If  $\mathcal{K} \subset S^3$  is a knot which has a  $2m$ -plat diagram satisfying the conditions of either Theorem 1.1 or [10, Theorem 1.1], except that twist regions that*

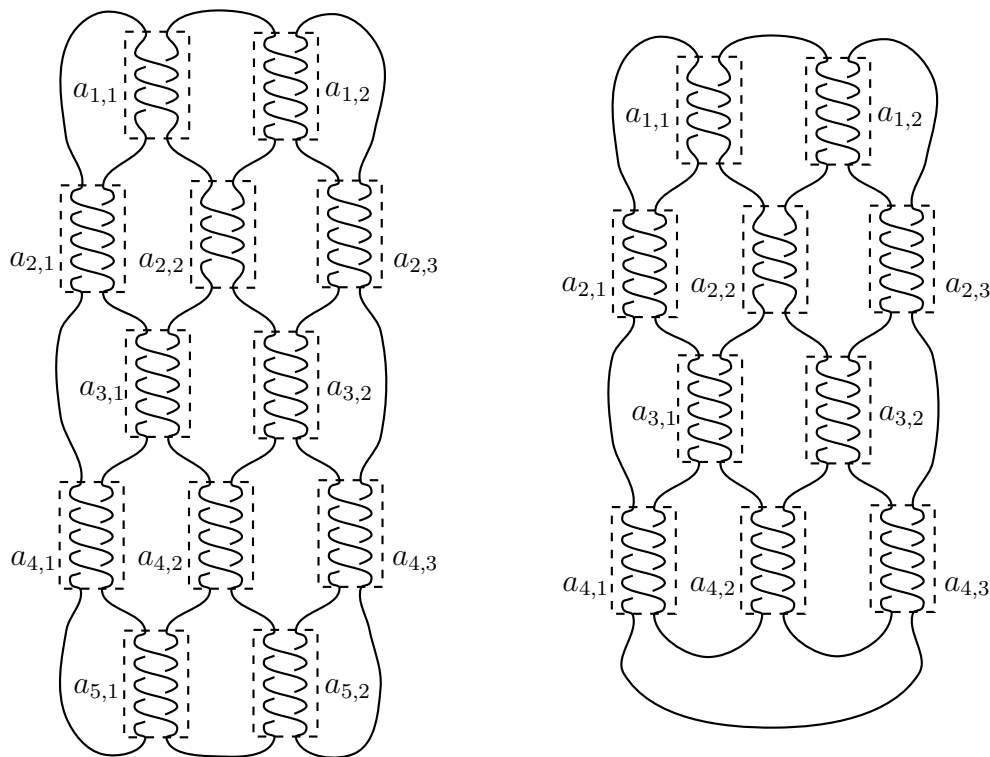

FIGURE 1. Left: A plat projection of a 3-bridge knot. For this example,  $a_{1,1} = a_{2,2} = -3$ , and all other  $a_{i,j} = -4$ . Right: An even plat projection of a 3-bridge knot.

are not at the top or bottom of the diagram, or are not the first or last in each row, are only required to be 1-highly twisted. Then the diagram is unique up to rotation in a vertical axis, or rotation in a vertical and horizontal axis, depending if the plat is even or odd respectively.

**Organization.** The organization of this paper deliberately mirrors that of [10], for ease of comparison of results, except in the places that the old arguments do not apply. In Section 2 we carefully define terms, introduce notation, and state previous results that we will bring to bear on the problem. In Section 3 we assume we have two distinct minimal plat projections of the same knot or link, and we show that there is an isotopy between them that has certain desirable properties. In Section 4, we use the isotopies to show that twist regions in one diagram are isotoped to twist regions in the other, with adjacent twist regions mapped to adjacent twist regions. This allows us to complete the proof of the main theorem.

## 2. PRELIMINARIES

First we review the definition of plat and e-plat projections. To illustrate these definitions, examples are given in Figure 1. The boxes labeled  $a_{i,j}$  in that figure are *twist regions* with  $a_{i,j}$  crossings of the same sign, either positive, negative, or zero

depending on the sign of  $a_{i,j}$ . We require that the twist regions be *reduced*, meaning the crossings within a twist region never have different signs, else a pair of crossings could be canceled and removed, simplifying the diagram.

Denote the twist region associated with the box labeled  $a_{i,j}$  by  $t_{i,j}$ . Then  $t_{i,j}$  is a projection of a  $1/a_{i,j}$ -tangle to the plane of projection  $P$ , where the tangle consists of strands of  $K$  lying in the 3-ball ( $\text{box} \times I$ ).

To carefully define a  $2m$  plat or e-plat projection, consider an element  $\mathcal{B}_{2m}$  in the braid group on  $2m-1$  generators  $\{\sigma_1, \dots, \sigma_{2m-1}\}$  with the following form. The element  $\mathcal{B}_{2m}$  be written as a concatenation of sub-words

$$\mathcal{B}_{2m} = b_1 \cdot b_2 \cdots b_{n-1},$$

where  $b_i$  satisfies the following:

- (1) When  $i$  is odd,  $b_i$  is a product of all  $\sigma_j$  with  $j$  even. Namely:

$$b_i = \sigma_2^{a_{i,1}} \cdot \sigma_4^{a_{i,2}} \cdots \sigma_{2m-2}^{a_{i,m-1}}$$

- (2) When  $i$  is even,  $b_i$  is a product of all  $\sigma_j$  with  $j$  odd. Namely:

$$b_i = \sigma_1^{a_{i,1}} \cdot \sigma_3^{a_{i,2}} \cdots \sigma_{2m-1}^{a_{i,m}}$$

On the top of the braids  $\mathcal{B}_{2m}$ , connect the strands by *bridges*: For each odd  $i \in \{1, \dots, 2m\}$  connect the  $i$ -th strand to the  $(i+1)$ -st strand by a bridge as in Figure 1.

On the bottom of the braids  $\mathcal{B}_{2m}$ , if  $n$  is odd then for even  $i \in \{2, \dots, 2m-2\}$  connect the  $i$ -th strand to the  $(i+1)$ -st strand by a bridge, and connect the first strand to the  $2m$ -th strand. If  $n$  is even then for each odd  $i \in \{1, \dots, 2m-1\}$  connect the  $i$ -th strand to the  $(i+1)$ -st strand by a bridge.

**Definition 2.1.** We say  $m$  is the *width* of the diagram and  $n$ , which equals the number of rows of twist regions plus one, is the *length*. In the case that  $n$  is even, the diagram is a *plat*. If  $n$  is odd, the diagram is an *even plat* or *e-plat*.

In Figure 1 left, there are five rows, so the length is  $n = 6$ . In Figure 1 right, there are 4 rows, so the length is 5.

**Remark 2.2.** Note the confusing terminology. If the diagram has an even number of rows of twist regions then its length  $n$  is odd and it is an even plat. If it has an odd number of rows then its length  $n$  is even and it is a plat.

It is a well-known fact that every knot or link in  $S^3$  admits a  $2m$  plat or e-plat projection, for appropriate  $m$ . This follows from Alexander's theorem, proved in 1923, that any link can be represented by a closed braid (see e.g. [2, p. 24]). Given a closed braid, pull strands of the braid closure across the diagram to obtain the plat or e-plat. In fact, any  $2m$  plat projection gives rise to a  $2m$  e-plat projection, and vice versa.

**Lemma 2.3.** *A knot has both odd and even minimal width plats.*

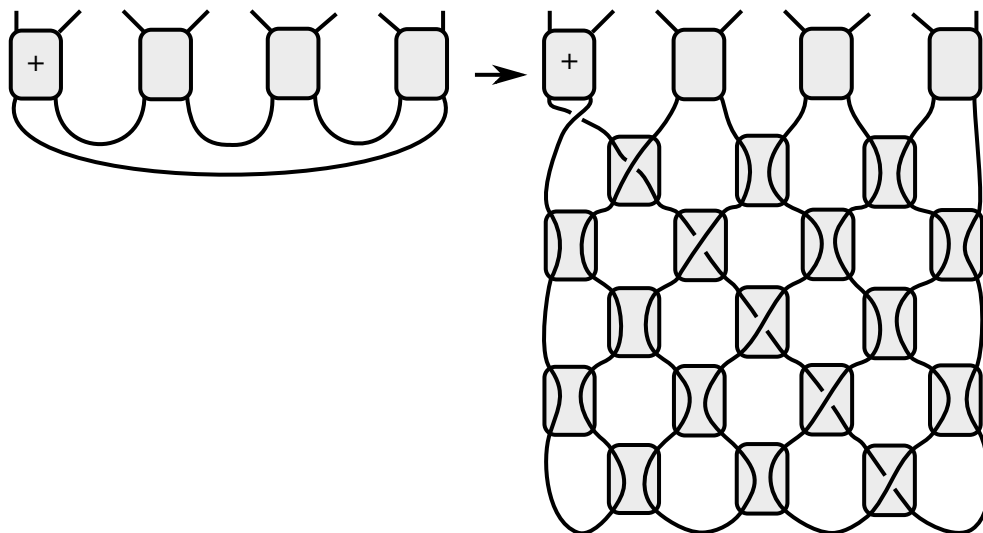

FIGURE 2. An *even* 4-plat gives rise to a corresponding odd 4-plat.

*Proof.* Starting with an even plat, pull the left-most strand on the bottom diagonally across the other strands at the bottom to form an odd plat; an example when  $m = 4$  is shown in Figure 2. The figure shows the case that in the original diagram, the bottom left twist region is positive. The strand goes under in this case so that a single crossing is added to that twist region (not subtracted). Additionally,  $m + 1$  rows are added with coefficients of 0 and  $+1$  in each twist region. If the bottom left twist region is negative, pull the diagonal strand over the others, again to add a single crossing to that twist region and form  $m + 1$  additional rows with coefficients of 0 and  $-1$ .

The proof to move from odd to even is similar. This time pull the strand that is next to the left-most strand diagonally across the diagram in a positive or negative fashion, adding a single crossing to the bottom left twist region and adding  $m + 1$  rows with coefficients 0 and  $\pm 1$  to the diagram.  $\square$

Note that in the proof of Lemma 2.3, isotoping from even to odd or vice versa entails adding twist regions with coefficients in  $\{0, \pm 1\}$ . However, our results will only apply to diagrams with twist regions with more crossings.

**Definition 2.4.** Let  $c \in \mathcal{N}$  be a constant. A  $2m$  plat or e-plat is *c-highly twisted* if  $|a_{i,j}| \geq c$  for all  $i, j$ . If a knot or link admits a *c-highly twisted* plat or e-plat projection, then it is a *c-highly twisted knot or link*.

The plat and e-plat in Figure 1 are both 3-highly twisted. Plats and e-plats obtained by isotopy in Figure 2 are not.

**Definition 2.5.** An  $m$ -bridge sphere of a knot or link  $\mathcal{K} \subset S^3$  is a 2-sphere which meets  $\mathcal{K}$  in  $2m$  points and cuts  $(S^3, \mathcal{K})$  into two  $m$ -string trivial tangles  $(B_1, \mathcal{T}_1)$  and  $(B_2, \mathcal{T}_2)$ . An  $m$ -string *trivial tangle* is a pair  $(B^3, \mathcal{T})$  consisting of a 3-ball  $B^3$  and a collection  $\mathcal{T}$  of  $m$  arcs properly embedded in  $B^3$  that are simultaneously isotopic into  $\partial B^3$  fixing  $\partial B^3$ .

**Definition 2.6** (Schubert [11] 1956). The *bridge number*  $b(\mathcal{K})$  of a knot or link  $\mathcal{K} \subset S^3$  is the minimal number of over-crossing arcs over all regular projections of  $\mathcal{K}$ . Equivalently, the bridge number is the minimal value of  $m$  such that  $\mathcal{K}$  has an  $m$ -bridge sphere; see [2, p. 23].

Notice that any  $2m$  plat or e-plat projection of  $\mathcal{K}$  has an  $m$ -bridge sphere, obtained by taking a 2-sphere in  $S^3$  that intersects the plane of projection in a horizontal line just below the maximum points of the plat or e-plat projection. Hence  $b(\mathcal{K}) \leq m$ .

In fact we can say something stronger for 3-highly twisted plats and e-plats. The following result, which follows by combining results of Johnson and Moriah [7] with work of Tomova [12] and Johnson and Tomova [8], plays an important role in our proofs for both the odd and even case.

**Theorem 2.7.** *Let  $K$  be a diagram of  $\mathcal{K} \subset S^3$  that is 3-highly twisted, has a plat or even plat projection of width  $m$  and length  $n$ , with  $m \geq 3$  and  $n > 4m(m - 2)$ . Then  $\mathcal{K}$  is an  $m$ -bridge knot or link, and it has a unique  $m$ -bridge sphere up to isotopy.*

**2.1. Horizontal bridge spheres and vertical 2-spheres.** We now define two families of surfaces, horizontal and vertical, that are important in our proof.

Given the diagram of a  $2m$  plat or e-plat, there is an obvious height function obtained by sweeping horizontally from the top bridges of the diagram at height  $t = 1$ , to the bottom bridges at height  $t = 0$ . In the case of the e-plat we must adjust the bottom height so that the arc from the first to  $2m$ -th strand has minimum height the same as the other arcs from  $k$ -th to  $(k + 1)$ -st strands. Now note that each height  $t \in (0, 1)$  corresponds to a bridge sphere.

**Definition 2.8.** With a height function defined on the diagram of the plat or e-plat as above, and  $t \in (0, 1)$ , there is a bridge sphere whose intersection with the plane of projection is the horizontal line of height  $t$ . Define this sphere to be a *horizontal* bridge sphere, and denote it by  $\Sigma_t$ .

Note that all horizontal bridge spheres  $\Sigma_t$  for  $0 < t < 1$  are isotopic. If the plat or e-plat projection further satisfies the hypotheses of Theorem 2.7, it follows that any bridge sphere is isotopic to a horizontal bridge sphere.

We can further define horizontal spheres at height  $t = 0$  and  $t = 1$ , but these do not meet  $K$  transversely, and meet  $K$  in only  $m$  points, so they are not bridge spheres.

In addition to horizontal bridge spheres, we will also consider *vertical* 2-spheres, first defined in [3]; see also [13].

**Definition 2.9.** Suppose  $K$  is a  $2m$  plat or e-plat projection of a knot or link and  $K$  has length  $n$ . Define an arc  $\alpha = \alpha(c_1, \dots, c_{n-1})$  on the plane of projection  $P$  to run monotonically from the top of the diagram to the bottom, intersecting  $K$  in exactly  $n$  points, such that  $\alpha$  is disjoint from all twist regions and has  $c_i$  twist regions to the left at the  $i$ -th row; see Figure 3. Connect endpoints of  $\alpha$  by a simple arc  $\beta \subset P$  that is disjoint from  $K$  so that  $\alpha \cup \beta$  has one maximum and one minimum with respect to

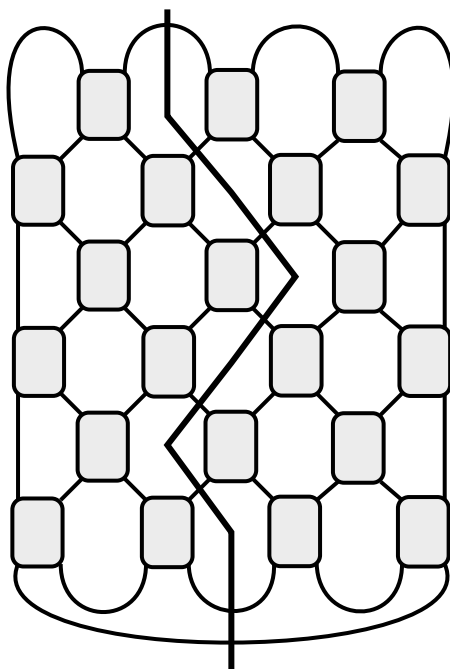

FIGURE 3. An arc  $\alpha$  in a 4-plat with  $n = 7$ .

the height function on  $P$ . Form a 2-sphere by attaching disks in front of and behind  $P$ . This 2-sphere is denoted by  $S = S(c_1, \dots, c_{n-1})$ .

If there is at least one twist region on each side of  $\alpha$  at each level, the 2-sphere  $S(c_1, \dots, c_{n-1})$  is called a *vertical 2-sphere*; see Figure 3.

If there is at least one twist region on each side of  $\alpha$  at each level except possibly level  $i$  for  $i$  odd, or levels  $i$  and  $i + 2$  for  $i$  odd, or levels  $i - 1$ ,  $i$ , and  $i + 1$  for  $i$  even, we say that  $S$  is an *almost vertical 2-sphere*. Note that the set of almost vertical 2-spheres contains the set of vertical 2-spheres.

For plats, vertical 2-spheres are known to be incompressible ([4, 13]), and we used this fact extensively in the proof of the odd plats case. For even plats, vertical 2-spheres are not necessarily incompressible. Thus the proofs in this paper must avoid using the incompressibility of vertical 2-spheres.

### 3. ISOTOPIES

We now begin the proof of Theorem 1.1 by setting up conditions on isotopies between an e-plat and a plat or e-plat. This section proceeds in an order similar to Section 3 of [10]. However, it deviates from that proof in a few key places.

Suppose a knot or link  $\mathcal{K} \subset S^3$  has an e-plat projection  $K'$  and another plat or e-plat projection  $K$ . It follows that the knot  $\mathcal{K}$  can embed in two ways, determined by the diagrams  $K'$  and  $K$ , respectively, in  $\varepsilon$ -neighborhoods of the projection planes  $P'$  and  $P$ . There is an ambient isotopy  $\varphi : (S^3, K') \rightarrow (S^3, K)$  taking  $K'$  to  $K$ . The

isotopy will take a vertical sphere  $S' \subset (S^3, K')$  to a sphere  $S = \varphi(S') \subset (S^3, K)$ , and a horizontal bridge sphere  $\Sigma' \subset (S^3, K')$  to some sphere  $\Sigma = \varphi(\Sigma') \subset (S^3, K)$ .

**Remark 3.1.** As in the odd case, we use the convention that objects relevant to the  $K'$  plat will be denoted by a  $'$ , for example  $S' \subset (S^3, K')$ . Those relevant to  $(S^3, K)$  will have no extra mark, for example  $S \subset (S^3, K)$ .

**Lemma 3.2.** *Let  $\mathcal{K} \subset S^3$  be a 3-highly twisted knot or link with an e-plat projection  $K'$  of width  $2m$ , and another plat or e-plat projection  $K$  also of width  $2m$ , where  $m \geq 3$ . Suppose  $n'$ , the length of  $K'$ , is greater than  $4m(m-2)$ . Let  $\varphi : (S^3, K') \rightarrow (S^3, K)$  be an isotopy. Then there exists an isotopy of pairs  $\psi : (S^3, K) \rightarrow (S^3, K)$  with the following properties.*

- (a) *Let  $S'$  be any almost vertical 2-sphere for  $K'$ , and let  $S = \varphi(S')$  be its image. The image  $\psi(S)$  is a 2-sphere meeting each horizontal bridge sphere of  $K$  in a single essential curve, so that any such curve meets  $K$  at most once.*
- (b) *For each horizontal bridge sphere  $\Sigma'_t$  for  $K'$ , the image  $(\psi \circ \varphi)(\Sigma'_t)$  is a horizontal bridge sphere  $\Sigma_t$  for  $K$ .*

*Proof.* The proof in the case of e-plats is identical to that of Lemma 3.2 of [10], using Theorem 2.7 in place of [10, Corollary 2.8].  $\square$

Lemma 3.4 below is analogous to [10, Lemma 3.3]. However it requires a new proof in the even  $r$  case. The proof uses the following lemma:

**Lemma 3.3.** *Let  $S'$  be a vertical 2-sphere with at least two twist regions on either side in each even row in  $K'$ . Then for each horizontal bridge sphere  $\Sigma_t$ , the curve  $S \cap \Sigma_t$  separates  $\Sigma_t$  into two disks, each disk meeting  $K$  at least three times.*

*Proof.* This is true in  $K'$ . By Lemma 3.2, the isotopy from  $(S^3, K')$  to  $(S^3, K)$  takes horizontal bridge spheres to horizontal bridge spheres, and takes  $S'$  to  $S$  with the same intersection pattern on  $\Sigma_t$ .  $\square$

Recall that each twist region  $t_{i,j}$  of  $K$  is the projection of a  $1/a_{i,j}$  tangle to the plane of projection  $P$ . Denote by  $B_{i,j}$  the bounded closed ball in  $S^3$  containing the tangle, where we choose the collection of all balls  $B_{i,j}$  to be disjoint. In addition, we restrict to a vertical 2-sphere with at least two twist regions on either side in each row. This is why the hypothesis  $m \geq 4$  is required.

**Lemma 3.4.** *Assume the same hypotheses on  $K'$  and  $K$  as in Lemma 3.2. In addition assume that  $m \geq 4$ . Choose a fixed vertical 2-sphere with at least two twist regions on either side in each even row. Then there is an isotopy  $\psi_2 : (S^3, K) \rightarrow (S^3, K)$  that preserves properties (a) and (b) of Lemma 3.2, and in addition does the following.*

- (c) *For all  $i, j$ ,  $\psi_2$  takes  $S$  to a surface either disjoint from  $B_{i,j}$  or running between the two strands of  $K$  in  $B_{i,j}$ .*



*Proof.*

Step 1: There is an ambient isotopy of  $(S^3, K)$  sending horizontal bridge spheres vertically, up and or down with respect to the height function, so that after the isotopy all intersections  $S \cap K$  lie outside of  $B_{i,j}$ . This isotopy will induce isotopies in each bridge sphere depending on the twist coefficients. After applying this isotopy, we may assume  $S \cap K$  lies outside of all balls  $B_{i,j}$ .

Step 2: Fix indices  $i, j$  and consider the intersection of  $S$  and  $S_{i,j} = \partial B_{i,j}$ . The components of the intersection are simple closed curves on  $S_{i,j}$ . Consider an innermost such curve of intersection on  $S_{i,j}$  and denote it by  $\gamma$ . There are several cases.

Case A: The curve  $\gamma$  lies entirely in a single horizontal bridge sphere  $\Sigma_a$  for some height  $a \in (0, 1)$ . In this case, note that,  $S \cap \Sigma_a$  is a single simple closed curve, so  $S \cap S_{i,j} = S \cap \Sigma_a$  by Lemma 3.2 (a).

The curve  $\gamma$  bounds a disk  $D$  in  $S_{i,j}$  that intersects  $K$  either 0, 1, or 2 times. In all cases, the curve  $\gamma$  also bounds a disk  $E$  in  $\Sigma_a$ . We claim that  $E$  meets  $K$  the same number of times as  $D$  meets  $K$ . This is because  $E \cup D$  is a sphere, with  $E$  horizontal. However  $K$  is monotonic with respect to the height function, so if a strand of  $K$  meets  $E$ , the strand must exit the sphere  $E \cup D$  by meeting  $D$ . In all cases, this contradicts Lemma 3.3. Thus  $\gamma$  cannot lie in a single horizontal level.

Case B: The curve  $\gamma$  does not lie entirely in a single horizontal level. In this case, we claim that  $\gamma$  has a single maximum and a single minimum with respect to the height function. For consider the intersection  $\gamma \cap \Sigma_t$  for some level  $t$ . Because  $\gamma$  is not horizontal, the intersection is a finite even set of points. If  $\gamma \cap \Sigma_t$  is nonempty, then there is an arc  $\alpha_t$  of  $S \cap \Sigma_t$  completely contained on one side of  $S_{i,j}$ , connecting two points of  $\gamma \cap \Sigma_t$ . Sweep up through  $\Sigma \times [t, b]$ , where  $b$  is the maximal point of  $S_{i,j}$ . By continuity, as we sweep up we obtain arcs  $\alpha_s$  for  $s \in (t, b)$  with endpoints on  $\gamma \cap \Sigma_s$ . The endpoints of  $\alpha_s$  form two arcs in  $(\Sigma \times [t, b]) \cap (S \cap S_{i,j})$  that must merge into a single arc, since  $S$  becomes disjoint from  $S_{i,j}$ . Similarly, sweeping down, the endpoints of  $\alpha_s \subset \gamma$  must form two arcs that merge into one as  $S$  sweeps through  $\Sigma \times [c, t]$ , where  $c$  is the minimal point of  $S_{i,j}$ . These form a closed curve, hence form all of  $\gamma$ .

We can assume therefore that  $\gamma$  lies in the range  $\Sigma \times [a, d]$  for some  $a, b$  satisfying  $c \leq a < d \leq b$ , and as  $\gamma$  is a curve on  $S_{i,j}$  with one maximum and one minimum,  $\gamma \cap \Sigma_t$  consists of two points for  $t \in (a, d)$ , and these points separate the closed curve  $S \cap \Sigma_t$  into two arcs  $\alpha_t$  and  $\beta_t$ .

Case B-1: The curve  $\gamma$  bounds a disk  $D$  on  $S_{i,j}$  that does not meet  $K$ . This case is illustrated in Figure 4, left. Then for all  $t \in (a, d)$ ,  $D \cap \Sigma_t$  is an arc  $\eta_t$  disjoint from  $K$ , and  $\alpha_t \cup \eta_t$  and  $\beta_t \cup \eta_t$  are closed curves that bound disks in  $\Sigma_t$ . Suppose one of the closed curves, say  $\alpha_t \cup \eta_t$ , bounds a disk that does not meet  $K$ . Then as we sweep up and down through  $\Sigma \times (a, d)$ , the arcs  $\alpha_s \cup \eta_s$  bound disks that cannot meet  $K$  for any  $s \in (a, d)$ ; this is because Step 1 implies no  $\alpha_s$  meets  $K$  and by assumption, no  $\eta_s$  meets  $K$ . Thus we conclude that the union of  $\alpha_s \cup \eta_s$  over all  $s \in [a, d]$  forms a 2-sphere bounding a ball disjoint from  $K$ . We may isotope  $S$  through the ball in a level-preserving manner, satisfying the conclusions of Lemma 3.2, to remove the curve  $\gamma$  from the intersections.

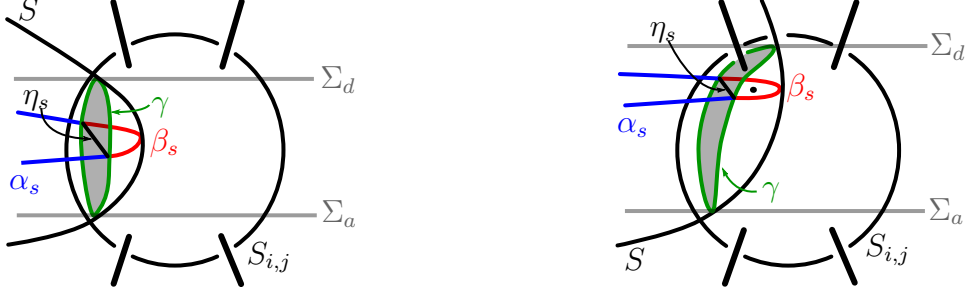

FIGURE 4. Left: The curve  $\gamma$  bounds a disk  $D$  on  $S_{i,j}$  that does not meet  $K$ . Right:  $\gamma$  bounds a disk  $D$  meeting  $K$  once.

Assume therefore that for fixed  $t \in (a, d)$ , both closed curves  $\alpha_t \cup \eta_t$  and  $\beta_t \cup \eta_t$  bound disks intersecting  $K$ , say  $n_t \geq 1$  and  $m_t \geq 1$  times, respectively. Let  $n_s$  and  $m_s$  denote the number of times the disks bounded by  $\alpha_s \cup \eta_s$  and  $\beta_s \cup \eta_s$  meet  $K$ , respectively, at level  $s \in (a, d)$ . Note that for any  $s$ , values  $n_s = n_t$  and  $m_s = m_t$  since  $K$  does not meet  $S$  in these levels, nor does it meet  $D \subset S_{i,j}$ . Now consider the maximal (highest) point of  $\gamma$ , on  $\Sigma_d$ . Since  $\gamma \cap \Sigma_d$  is a single point, it separates  $S \cap \Sigma_d$  into a single arc. By continuity, as  $s \rightarrow d$  one of the closed curves  $\alpha_s \cup \eta_s$  or  $\beta_s \cup \eta_s$  converges to the single point  $\gamma \cap \Sigma_d$  and the other curve converges to  $S \cap \Sigma_d$ . Thus on the one hand, disks bounded by  $\alpha_s \cup \eta_s$  and  $\beta_s \cup \eta_s$  meet  $K$  a total of  $n_s \geq 1$  and  $m_s \geq 1$  times, respectively, but on the other hand, one of these disks converges to a point disjoint from  $K$  as  $s \rightarrow d$ . This is a contradiction.

Case B-2: The curve  $\gamma$  bounds a disk  $D$  on  $S_{i,j}$  meeting  $K$  exactly once, as illustrated in Figure 4, right. Let  $t \in (0, 1)$  be such that  $D \cap \Sigma_t$  meets  $K$ . Again let  $\eta_t$  denote the arc  $D \cap \Sigma_t$ . Consider again the closed curves  $\alpha_s \cup \eta_s$  and  $\beta_s \cup \eta_s$  for  $s \in (a, t)$  and  $s \in (t, d)$ . For  $s > t$ , one of the closed curves, say  $\alpha_s \cup \eta_s$ , bounds a disk in  $\Sigma_s$  meeting  $K$  at least once: This intersection corresponds to the arc of  $K$  running up from  $K \cap D$ . For  $s < t$ , the other closed curve  $\beta_s \cup \eta_s$  bounds a disk in  $\Sigma_s$  meeting  $K$  at least once, corresponding now to the arc of  $K$  running down from  $K \cap D$ . As in the previous case B-1, if there are any other intersections of these disks with  $K$ , then there are the same number of intersections for  $s \in (a, t)$  and for  $s \in (t, d)$ . However, as in the previous case consider the maximum and minimum points of  $\gamma$ . At the maximum,  $\beta_d \cup \eta_d$  collapses to a single point. Hence for  $s \in (t, d)$ , the curve  $\beta_s \cup \eta_s$  cannot bound a disk meeting points of  $K$ . Thus for  $s \in (a, t)$ , the curve  $\beta_s \cup \eta_s$  bounds a disk meeting only one point of  $K$ , coming from the intersection of  $K$  with  $D$ . By a symmetric argument, for  $s \in (a, t)$ , the curve  $\alpha_s \cup \eta_s$  bounds a disk that cannot meet  $K$ , and for  $s \in (t, d)$ , the curve  $\alpha_s \cup \eta_s$  bounds a disk that meets  $K$  only once. Then it follows that  $\alpha_t \cup \beta_t = S \cap \Sigma_t$  bounds a disk meeting  $K$  exactly once, in  $D \cap K$ . But this contradicts Lemma 3.3.

Case B-3: The curve  $\gamma$  bounds a disk  $D$  on  $S_{i,j}$  meeting  $K$  exactly twice. Note that the four intersection points of  $S_{i,j} \cap K$  occur on two levels where each level contains exactly two points. Denote these levels by  $\Sigma_r$  and  $\Sigma_t$  with  $r < t$ . Again there are two

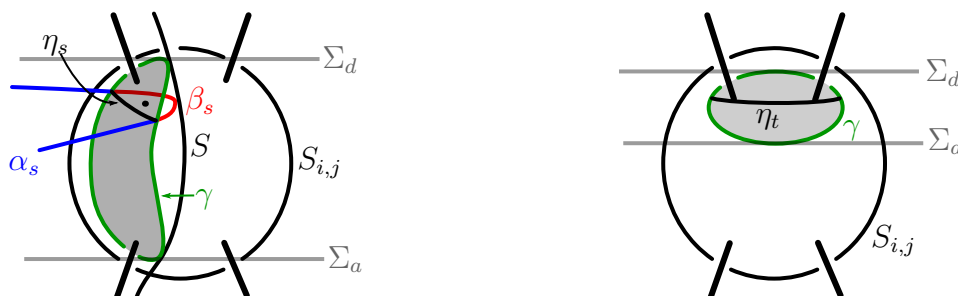

FIGURE 5. Left:  $\gamma$  bounds a disk  $D$  on  $S_{i,j}$  that meets  $K$  twice on different levels. Right: disk  $D$  meets  $K$  twice on the same level.

cases, namely that the two intersection points of  $D \cap K$  are on different levels, or that the two intersection points are on the same level.

Case B-3-a: The intersections  $D \cap K$  occur on different levels  $\Sigma_r$  and  $\Sigma_t$ . This case is illustrated in Figure 5, left. Again let  $\eta_s$  denote  $D \cap \Sigma_s$ . Then  $K$  meets  $\eta_s$  when  $s = r$  and when  $s = t$ . Note that the minimum height  $a$  of  $\gamma$  satisfies  $a < r$  and the maximum satisfies  $d > t$ . The closed curves  $\alpha_s \cup \eta_s$  and  $\beta_s \cup \eta_s$  bound disks on  $\Sigma_s$  meeting  $K$ . For  $s \in (t, d)$ , one of the curves, say  $\alpha_s \cup \eta_s$ , bounds a disk meeting the arc of  $K$  running up from  $D$ . For  $s \in (r, t)$ , the other curve  $\beta_s \cup \eta_s$  bounds a disk meeting an arc of  $K$ . This arc is on the opposite side of  $D$  in this range. Finally, for  $s \in (a, r)$ , again  $\alpha_s \cup \eta_s$  must bound a disk meeting the arc of  $K$  running down from  $D$ . It follows by continuity that at the minimum point of  $\gamma$  the curve  $\beta_a \cup \eta_a$  collapses to a single point, and similarly  $\beta_d \cup \eta_d$  collapses to a single point at the maximum of  $\gamma$ . By a similar argument as above, it follows that  $\beta_s \cup \eta_s$  bounds a disk meeting  $K$  only once in the range  $(r, t)$ , and not at all in the range  $(a, r) \cup (t, d)$ . This configuration determines a disk running between the two strands of  $K$  in the twist region, as desired.

Case B-3-b: The intersections  $D \cap K$  occur on the same level, say on the level  $\Sigma_t$ , as illustrated in Figure 5, right. Then the maximum height  $d$  of  $\gamma$  must occur at a level above  $t$ , and the minimum height  $a$  of  $\gamma$  must occur at a level below  $t$  but above  $r$ . Again consider the closed curves  $\alpha_s \cup \eta_s$  and  $\beta_s \cup \eta_s$  for  $s \in (a, d)$ . Note that no arc  $\alpha_s$  or  $\beta_s$  intersects  $K$  for  $s$  in this range, and  $\eta_s$  intersects  $K$  only when  $s = t$ , and then  $\eta_t$  intersects  $K$  twice. Thus for  $s > t$ , one of the curves  $\alpha_s \cup \eta_s$  or  $\beta_s \cup \eta_s$ , say  $\alpha_s \cup \eta_s$ , bounds a disk meeting  $K$  two more times than the disk bounded by  $\alpha_s \cup \eta_s$  for  $s < t$ . Similarly  $\beta_s \cup \eta_s$  for  $s > t$  bounds a disk meeting  $K$  two fewer times than the disk bounded by  $\beta_s \cup \eta_s$  for  $s < t$ . Again consider the heights  $a$  and  $d$ . At level  $d$ ,  $\Sigma_d$  meets  $\gamma$  in a single point, and  $\eta_d$  collapses to that single point. Thus  $\beta_d$  collapses to a single point and  $\alpha_d$  closes up to be a closed curve meeting this point. As above, it follows that for  $s \in (t, d)$ ,  $\beta_s \cup \eta_s$  bounds a disk disjoint from  $K$ . A similar argument at level  $a$  implies that for  $s \in (a, t)$ ,  $\alpha_s \cup \eta_s$  bounds a disk disjoint from  $K$ . It follows that for  $s \in (t, d)$ ,  $\alpha_s \cup \eta_s$  bounds a disk meeting  $K$  exactly twice, and at level  $d$ ,  $\alpha_d = S \cap \Sigma_d$  is a closed curve bounding a disk meeting  $K$  exactly twice. This contradicts Lemma 3.3.  $\square$

We now use the previous lemmas to show that  $\varphi(S')$  does not meet twist regions. The proof is similar to that of [10, Proposition 3.4]. Since it is a fundamental argument in the paper, we include it again here.

**Proposition 3.5.** *Let  $K'$  be a  $2m$  e-plat projection of a knot or link  $\mathcal{K} \subset S^3$ , where  $m > 4$ , the length  $n'$  of  $K'$  is greater than  $4m(m-2)$ , and  $K'$  is 3-highly twisted. Let  $K$  be another  $2m$  plat or e-plat projection of  $\mathcal{K} \subset S^3$  and assume that  $K$  is 1-highly twisted. Suppose  $S'$  is a vertical 2-sphere for  $K'$  which has at least two twist regions on each even row. Then the isotopy of Lemma 3.4 takes  $S'$  to a 2-sphere  $S$  that does not meet any twist regions.*

*Proof.* Let  $\varphi : (S^3, K') \rightarrow (S^3, K)$  be an isotopy satisfying the conclusions of Lemmas 3.2 and 3.4 for  $S'$ . Assume by way of contradiction that  $S$  runs through a twist region. By Lemma 3.4, it runs between the two strands of the twist region. Let  $\Sigma_c$  and  $\Sigma_d$  be horizontal bridge spheres just below and above the twist region, respectively. The region between  $\Sigma_c$  and  $\Sigma_d$  is homeomorphic to  $\Sigma \times [c, d]$ , where  $\Sigma$  is a  $2m$  punctured disk. Again by Lemma 3.4, since  $S$  does not meet  $K$  in twist regions, we can choose  $c$  and  $d$  so that  $S$  does not meet  $K$  in the region  $\Sigma \times [c, d]$ . There is an isotopy  $\zeta$  from  $\Sigma_c$  to  $\Sigma_d$  given by sweeping through the horizontal bridge spheres. The isotopy can be arranged to be the identity away from disks bounding points of  $K$  in a twist region. It is a nontrivial Dehn twist, twisting an amount equal to the number of crossings in the twist region, inside a disk bounding points of  $K$  in a twist region. In particular, the isotopy  $\zeta$  takes the simple closed curve  $\gamma = S \cap \Sigma_c$  in  $\Sigma \times \{c\}$  to a distinct curve  $\zeta(\gamma)$  in  $\Sigma \times \{d\}$ , given by a Dehn twist.

Now consider the effect of  $\varphi^{-1}$  on  $\Sigma \times [c, d]$ . By Lemma 3.2, the isotopy takes this region to a region  $\Sigma' \times [a, b]$ , with  $\Sigma'_a$  the image of  $\Sigma_c$ , and  $\Sigma'_b$  the image of  $\Sigma_d$ . The portion of the surface  $S$  between levels  $c$  and  $d$  is taken to a portion of the surface  $S'$  between levels  $a$  and  $b$ . By Definition 2.9, the surface  $S'$  does not run through any twist regions. Moreover, since  $S$  avoids  $K$  in  $\Sigma \times [c, d]$ , region,  $S'$  must avoid  $K'$  in the region  $\Sigma' \times [a, b]$ .

But again, there is an isotopy  $\zeta'$  from  $\Sigma'_a$  to  $\Sigma'_b$  given by sweeping through horizontal bridge spheres, and again this isotopy can be taken to be the identity away from twist regions. Because  $S'$  does not run through any twist regions, it must take the curve  $\gamma' = S' \cap \Sigma'_a$  on  $\Sigma' \times \{a\}$  to the same curve  $\zeta'(\gamma') = \gamma'$  on  $\Sigma' \times \{b\}$ .

On the other hand, we know

$$\zeta(\gamma) = \varphi \circ \zeta' \circ \varphi^{-1}(\gamma) = \varphi \circ \zeta'(\gamma') = \varphi(\gamma') = \gamma.$$

But this implies that the Dehn twist  $\zeta$  is trivial. This contradicts the fact that  $K$  is 1-highly twisted.  $\square$

**Remark 3.6.** The above proof uses crucially the fact that the diagram of  $K'$  is fixed, and the twist regions are reduced. In general, an isotopy between bridge surfaces in an arbitrary diagram could first spin around a twist region, then spin in the opposite direction, undoing the twists. However, this would result in a twist region that is not reduced. The map  $\zeta'$  above is completely determined by the reduced diagram, and cannot create crossings that can be removed in a different level.

From here, given an isotopy  $\varphi : (S^3, K') \rightarrow (S^3, K)$  satisfying the hypotheses of Proposition 3.5, we may take another isotopy satisfying the conclusions of Lemmas 3.2 and 3.4. Therefore, from now on, we will compose the initial isotopy  $\varphi$  with this new isotopy, and denote the composition by  $\varphi$ . Thus we assume that  $\varphi$  satisfies the conclusions of previous lemmas for a fixed  $S'$ .

**Lemma 3.7.** *Let  $K'$  be a  $2m$  e-plat projection of a knot or link  $\mathcal{K} \subset S^3$  so that  $m \geq 4$ , the length  $n'$  of  $K'$  is greater than  $4m(m - 2)$  and  $K'$  is 3-highly twisted. Let  $K$  be another  $2m$  plat or e-plat projection of  $\mathcal{K} \subset S^3$  and assume that  $K$  is 1-highly twisted. Let  $S'$  be a vertical 2-sphere for  $K'$  and let  $\varphi : (S^3, K') \rightarrow (S^3, K)$  be an isotopy (satisfying the conclusions of isotopies above), with  $S = \varphi(S')$ . Then in any level between twist regions,  $S$  meets the diagonal segments of  $K$  at most once. In particular,  $S$  cannot meet a segment of  $K$  in a point on the outside of an odd level.*

*Proof.* The proof is identical to that of [10, Lemma 3.8]: the argument takes place within the braid, on levels between rows of twist regions, and there is no difference between diagrams of plats and e-plats there.  $\square$

We now introduce names for regions of the e-plat diagram. The definition below agrees with [10, Definition 4.2], except there is an additional region.

**Definition 3.8.** Let  $\mathcal{K} \subset S^3$  be a knot or link with a  $2m$  e-plat projection  $K'$ . Enclose every twist region of  $K'$  in a box  $t_{i,j} = (\text{twist region}) \times [-\varepsilon, \varepsilon]$ . This divides  $P \setminus (K \cup (\cup_{i,j} t_{i,j}))$  into regions, for example the regions shown in Figure 3. Up to symmetry, there are five different types:

- (1) A unique unbounded region, denoted by  $\mathcal{U}$ .
- (2) Regions with four edges that are segments of  $K$ . We call such a region *generic*, and denote it by  $\mathcal{Q}$ .
- (3) One region with  $m$  edges at the very bottom denoted by  $\mathcal{M}$ .
- (4) Regions with three edges that are segments of  $K$ . These appear on the top, just above  $\mathcal{M}$  on the bottom, and on the left-most or right-most sides, but not in a corner. These regions will be called *triangular*, and we denote them by  $\mathcal{T}^t$ ,  $\mathcal{T}^b$ ,  $\mathcal{T}^l$ , and  $\mathcal{T}^r$  respectively.
- (5) Two regions with two edges that are segments of  $K$ . These appear in the top corners and are denoted  $\mathcal{B}^{t,l}$ ,  $\mathcal{B}^{t,r}$ .

**Lemma 3.9.** *Let  $K'$  be a  $2m$  e-plat projection of the knot or link  $\mathcal{K} \subset S^3$  such that  $m \geq 4$  and  $K'$  is 3-highly twisted. Let  $K$  be a  $2m$  plat or e-plat projection for  $\mathcal{K} \subset S^3$  and assume and  $K$  is 1-highly twisted. Let  $S'$  be a vertical 2-sphere for  $K'$  which has at least two twist regions on either side in each even row. Let  $\varphi$  be an isotopy between  $K'$  and  $K$  satisfying the conclusions of Lemmas 3.2 and 3.4. Then in each row of twist regions,  $S = \varphi(S')$  meets exactly one region of the diagram of  $K$  besides  $\mathcal{U}$ . Similarly, it meets  $\mathcal{M}$  exactly once.*

*Proof.* Note that  $S$  intersects  $K$  in  $n'$  points because  $S'$  intersects  $K'$  in  $n'$  points. Thus  $S$  must meet some region besides  $\mathcal{U}$ . If  $S$  meets a generic region, then by Lemma 3.7 it must enter and exit the region on different rows of diagonal segments. Thus  $S$  meets a region in the row just above that generic region and one in the row just below.

If  $S$  meets a triangular region on the left or right, then it cannot meet the arc of  $K$  to the left or right (respectively), so it must enter and exit the region by meeting the diagonal segments on the rows above and below. Thus  $S$  meets a region besides  $\mathcal{U}$  just above and just below the region in this case as well.

If  $S$  meets a triangular region on the top or on the bottom, it must enter along the top or bottom and exit through a different segment of the diagram. Thus it will meet a region besides  $\mathcal{U}$  just below or above (respectively) in this case.

If  $S$  meets the region  $\mathcal{M}$ , it must meet it by intersecting two different arcs of  $K$ , thus it must run into a triangular region. In all cases,  $S$  must meet at least one region besides  $\mathcal{U}$  on every row.

Finally, Lemma 3.7 implies  $S$  cannot meet two distinct regions besides  $\mathcal{U}$  in any level, else it would meet  $K$  in the same row of diagonal segments between twist regions.  $\square$

**Corollary 3.10.** *Let  $K'$  be a  $2m$  e-plat projection of the knot or link  $\mathcal{K} \subset S^3$  such that  $m \geq 4$  and  $K'$  is 3-highly twisted. Let  $K$  be a  $2m$  plat or e-plat projection for  $\mathcal{K} \subset S^3$  that is 1-highly twisted. If  $n, n'$  are the respective lengths of the plats  $K$  and  $K'$ , with  $n'$  satisfying  $n' > 4m(m - 2)$ , then  $n = n'$ . In particular  $K$  is an  $2m$  e-plat.*

*Proof.* Let  $S'$  be a vertical 2-sphere for  $K'$  with at least two twist regions on each even row. Let  $\varphi$  be an isotopy and let  $S = \varphi(S')$  as usual. Since  $S'$  meets  $K'$  a total of  $n'$  times,  $S$  also meets  $K$  a total of  $n'$  times. Note by the pigeonhole principle and Lemma 3.7,  $n \geq n'$  and by Lemma 3.9,  $n' = n$ .  $\square$

The proof of the following corollary avoids using incompressibility of vertical 2-spheres.

**Corollary 3.11.** *If  $S'$  is a vertical sphere, and  $S = \varphi(S')$ , then the intersection of  $S$  with the projection plane  $P$  contains precisely one simple closed curve  $\delta$  so that  $\delta \cap K \neq \emptyset$  and contains all  $n$  points of intersection with  $K$ .*

*Proof.* The proof follows immediately from Lemma 3.9.  $\square$

#### 4. IMAGES OF PLATS

As in [10], this section is divided into subsections. In the first, we show that we may take our isotopy between the  $2m$  e-plat projections to take all almost vertical 2-spheres to almost vertical 2-spheres simultaneously. In the second, we use vertical 2-spheres to isolate twist regions, and we show that they must map under the isotopy to twist regions with the same relative position. This allows us to complete the proof.

**4.1. Images of vertical 2-spheres.** The main result of this subsection is the following theorem:

**Theorem 4.1.** *Let  $K', K$  be  $2m$  e-plat projections of the same knot or link  $\mathcal{K}$ . Assume  $m \geq 4$ , the length  $n'$  of  $K'$  satisfies  $n' > 4m(m - 2)$ , and  $K'$  is 3-highly twisted. Then we may isotope  $\varphi : (S^3, K') \rightarrow (S^3, K)$  so that it maps all almost vertical 2-spheres in  $(S^3, K')$  to almost vertical 2-spheres in  $(S^3, K)$  simultaneously.*

To prove the theorem, we first need some preliminary definitions and results.

**Lemma 4.2.** *Let  $K'$  be a  $2m$  e-plat projection of the knot or link  $\mathcal{K} \subset S^3$  such that  $m \geq 4$  and  $K'$  is 3-highly twisted. Let  $K$  be a  $2m$  plat projection of  $\mathcal{K} \subset S^3$  and assume  $K$  is 1-highly twisted. Suppose  $n'$  and  $n$  are the respective lengths of  $K'$  and  $K$  with  $n'$  satisfying  $n' > 4m(m - 2)$ . Finally, let  $S' \subset (S^3, K')$  be a vertical 2-sphere which has at least two twist regions on each even row, and let  $\varphi : (S^3, K') \rightarrow (S^3, K)$  be an isotopy satisfying Lemmas 3.2 and 3.4. Then  $\varphi(S') = S$  is a vertical 2-sphere in  $(S^3, K)$ .*

*Proof.* By Corollary 3.11,  $S$  intersects the projection plane  $P$  in precisely one simple closed curve  $\delta$ . By Lemma 3.7, that curve  $\delta$  meets diagonal segments of  $K$  at most once in any level between twist regions. By Corollary 3.10, the number of intersections  $|S \cap K| = |S' \cap K'| = n' = n$ , and by Lemma 3.3,  $\delta$  has two twist regions on either side. Thus the curve must be exactly the intersection of a vertical 2-sphere for  $K$  with the projection plane, and  $S$  must be obtained by capping off disks in front of and behind the projection plane with boundary on  $\delta$ . Thus  $S$  is a vertical 2-sphere with at least two twist regions on either side.  $\square$

The vertical and almost vertical 2-spheres form a collection of surfaces that isolate twist regions of the diagram. This motivates the following definition, which was originally [10, Definition 4.6].

**Definition 4.3.** Let  $S'_1 = S'_1(c_1, \dots, c_i, \dots, c_{n-1}) \subset (S^3, K')$  be a vertical or almost vertical 2-sphere and let  $S'_2 \subset (S^3, K')$  be an almost vertical 2-sphere that is different from  $S'_1$  by a single twist region in the  $i$ -th row. Without loss of generality,  $S'_2 = S'_2(c_1, \dots, c_i + 1, \dots, c_{n-1})$ . The bounded component  $B'$  of  $S^3 \setminus (S'_1 \cup S'_2)$  is a rational 2-tangle  $B'_{i, c_i+1}$  as in Figure 6, containing the  $t'_{i, c_i+1}$  twist region. Vertical 2-spheres  $S'_1$  and  $S'_2$  intersect in a disk, and  $S'_1 \setminus (S'_1 \cap S'_2)$  is a disk  $\Delta'_1$  meeting  $K'$  in two points. Similarly,  $S'_2 \setminus (S'_1 \cap S'_2)$  is a disk  $\Delta'_2$  meeting  $K'$  in two points. Let  $\Omega'$  denote the union  $\Delta'_1 \cup \Delta'_2$ . We say  $\Omega'$  is an *isolating 2-sphere*. Note it is a 2-sphere meeting  $K'$  four times.

By Lemma 4.2, there is at least one vertical 2-sphere  $S'_1$  in  $K'$  that is mapped by isotopy to a vertical 2-sphere in  $K$ . The following proposition considers almost vertical 2-spheres which is different from such a 2-sphere by one twist region.

**Proposition 4.4.** *Let  $K'$  and  $K$  be two  $2m$  e-plat projections of the same knot or link. Let  $\varphi : (S^3, K') \rightarrow (S^3, K)$  be an isotopy taking a fixed almost vertical 2-sphere  $S'_1$  to an almost vertical 2-sphere  $S_1 = \varphi(S'_1)$ , and satisfying the conclusions of Lemmas 3.2 and 3.4. Let  $S'_2$  be an almost vertical 2-sphere that differs from  $S'_1$  in one twist region*

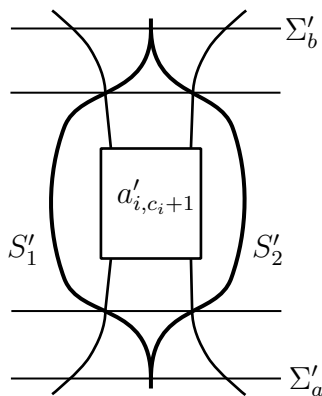

FIGURE 6. An isolating 2-sphere  $\Omega'$ . Figure originally from [10]

in one row. Let  $\Sigma'_a$  and  $\Sigma'_b$  denote the horizontal bridge spheres at the top and bottom of that row. Then there exists an isotopy  $\psi : (S^3, K) \rightarrow (S^3, K)$  that satisfies:

- (1)  $\psi$  preserves the conclusions of Lemma 3.2 and 3.4,
- (2) it fixes the tangle outside  $S_1$ ,  $\varphi(\Sigma'_a)$ , and  $\varphi(\Sigma'_b)$ , and
- (3) it takes  $\varphi(S'_2)$  to an almost vertical 2-sphere that differs from  $S_1$  in one twist region in one row.

*Proof.* The proof begins the same as the proof of [10, Proposition 4.8]. Take disks  $\Delta'_1$  and  $\Delta'_2$  as in Definition 4.3. The image  $\varphi(S'_1 \cap S'_2)$  is a disk in the almost vertical 2-sphere  $\varphi(S'_1) = S_1$ .

Let  $\Sigma'_a$  and  $\Sigma'_b$  denote horizontal bridge spheres meeting  $\partial\Delta'_1$  and  $\partial\Delta'_2$  in a single point at the bottom and top, respectively, as in Figure 6. By Lemma 3.2,  $\Delta_1 = \varphi(\Delta'_1)$  and  $\Delta_2 = \varphi(\Delta'_2)$  lie in a region between horizontal bridge spheres  $\Sigma_c = \varphi(\Sigma'_a)$  and  $\Sigma_d = \varphi(\Sigma'_b)$ . Since  $\Delta_1 \subset S_1$  meets  $K$  twice,  $\Sigma_c$  and  $\Sigma_d$  must bound a region  $\Xi$  homeomorphic to  $S^2 \times I$  in  $(S^3, K)$  containing a single row of twist regions. Both  $\Delta_1$  and  $\Delta_2$  lie in  $\Xi$  between  $\Sigma_c$  and  $\Sigma_d$ .

There is exactly one almost vertical 2-sphere  $S$  that differs from  $S_1$  in a single twist region in  $\Xi$ , and we will show that we may isotope  $S_2 = \varphi(S'_2)$  to  $S$  in  $\Xi$ . The argument given in [10] shows this using the incompressibility of vertical 2-spheres, but as mentioned above this is not true for  $e$ -plats, so the proof is modified to deal with this case.

Ensure that  $S$  meets  $K$  exactly in the points that  $S_2$  meets  $K$ ; we do this by ensuring  $S'_2$  and  $S'_1$  meet  $K'$  at the same levels where they differ, and so map to the same levels in  $K$ . Now denote the tangle containing the twist region between  $S_1$  and  $S$  by  $(B_{r,s}, t_{r,s})$ , and let  $\Delta = S \setminus (S \cap S_1)$ . We may assume the sphere  $\partial B_{r,s}$  is disjoint from the sphere  $\Delta_1 \cup \Delta$ , with  $\partial B_{r,s}$  in the interior of the ball bounded by  $\Delta_1 \cup \Delta$ .

Now we show  $\Delta_2$  is disjoint from  $\partial B_{r,s}$ . For suppose not. Then  $\Delta_2 \cap \partial B_{r,s}$  is a collection of closed curves.



Suppose one curve of  $\Delta_2 \cap \partial B_{r,s}$  bounds a disk on  $\partial B_{r,s}$  that does not meet  $K$ . Then there is an innermost such disk  $E$  on  $\partial B_{r,s}$ . First suppose that  $\partial E$  bounds a disk  $D$  on  $\Delta_2$ , disjoint from  $K$ . Then  $E \cup D$  bounds a 3-ball in  $\Xi \setminus \mathcal{N}(K)$  between  $\Sigma_c$  and  $\Sigma_d$ . Isotope horizontally in the ball, preserving levels, to remove this intersection. Next, note the disk  $D \subset \Delta_2$  cannot intersect  $K$  in a single point, for then  $E \cup D$  intersects  $K$  in a single point. So  $D$  intersects  $K$  in two points, namely the two points of  $K \cap \Delta$ , and  $\partial D$  is isotopic in  $\Xi \setminus \mathcal{N}(K)$  to  $\partial \Delta_2 = \partial \Delta \subset S$ . But this is impossible:  $\partial D = \partial E$  bounds a disk disjoint from  $K$  in  $\partial B_{r,s}$ . No such disk exists.

So suppose each curve of  $\Delta_2 \cap \partial B_{r,s}$  bounds a disk on  $\partial B_{r,s}$  that meets  $K$ ; suppose an innermost such disk  $E$  meets  $K$  exactly once. Then  $\partial E$  cannot bound a disk  $D \subset \Delta_2$  with  $D \cap K = \emptyset$ , or with  $D$  meeting  $K$  in two points. So  $\partial E$  bounds a disk  $D \subset \Delta_2$  meeting  $K$  exactly once. Then  $E \cup D \setminus K$  is a twice punctured sphere, punctured by the same segment  $K_1$  of  $K \cap \Xi$ . Thus the tangle  $(E \cup D, K_1)$  is a trivial 1-tangle and the disk  $E$  is isotopic to the disk  $D$ . Isotope in a level-preserving manner to remove the intersection.

So if there are curves of intersection of  $\Delta_2 \cap \partial B_{r,s}$ , they each bound a disk on  $\partial B_{r,s}$  meeting two points of  $K$ . Note that  $\Delta_2$  is disjoint from the plat  $K$  in  $(B_{r,s}, t_{r,s})$  as all possible intersections  $K \cap \Delta_2$  have been accounted for. Thus if  $\partial B_{r,s} \cap \Delta_2$  is nonempty, the only possibility is that  $\Delta_2$  is parallel to the unique compressing disk for the tangle  $(B_{r,s}, t_{r,s})$  separating the tangle into two trivial tangles. Since  $K$  is 1-highly twisted,  $\partial \Delta_2$  must meet the interior of  $\Delta_1$ . This contradicts the fact that the interior of  $\Delta'_1$  is disjoint from  $\Delta'_2$ .

It follows that  $\Delta_2$  is disjoint from  $\partial B_{r,s}$ , hence from  $B_{r,s}$ . A similar argument to that above implies that  $\Delta_2$  can be isotoped in a level-preserving manner to be disjoint from other tangles  $(B_{j,s}, t_{j,s})$  in  $\Xi$ . Then  $\Delta_2$  lies in the trivial tangle between  $\Sigma_c$ ,  $\Sigma_d$ , and disks outside of twist regions in  $\Xi$ . It has boundary meeting  $\partial \Delta_1 = \partial \Delta$ , and meets  $K$  in the points  $K \cap \Delta$ . It follows that  $\Delta_2$  is parallel to  $\Delta$ . Since both  $\Delta_2$  and  $\Delta$  meet each level in a single arc, we may isotope  $\Delta_2$  horizontally to  $\Delta$ .

Note all the isotopies above satisfy (1) and (2) of the lemma, so their composition satisfies the lemma.  $\square$

*Proof of Theorem 4.1.* Since  $m \geq 4$ , there is a vertical 2-sphere  $S' = S'(c_1, \dots, c_{n-1}) \subset (S^3, K')$  with at least two twist regions on each side. By Lemma 4.2 the 2-sphere  $S = \varphi(S') \subset (S^3, K)$  is a vertical 2-sphere.

Let  $S'_v$  be an almost vertical 2-sphere that differs from  $S'$  by a single isolating 2-sphere. By Proposition 4.4, we may adjust the isotopy  $\varphi$  to take  $S'_v$  to an almost vertical 2-sphere differing from  $\varphi(S')$  by a single isolating 2-sphere. By induction, adjust  $\varphi$  one twist region at a time to obtain an isotopy taking each almost vertical 2-sphere to an almost vertical 2-sphere, fixing the previously adjusted vertical and almost vertical 2-spheres. This proves the theorem.  $\square$

**4.2. Matching twist regions to twist regions.** From now on, the proof of Theorem 1.1 follows the proof of the odd case  $r$ , as we have overcome the problems that could be caused by the possible compressibility of vertical 2-spheres when  $r$  is even.

**Definition 4.5.** An *allowable twist region* is a twist region that can be isolated by  $\Omega' = \Delta'_1 \cup \Delta'_2$  for  $\Delta'_1, \Delta'_2$  coming from vertical 2-spheres. Allowable twist regions do not lie on the far left or far right of the diagram. An *almost allowable twist region* is one that lies on the far left or far right, but not in one of the top corners. That is, it is a twist region  $t'_{i,j} \in K'$  such that either  $i$  is odd with  $3 \leq i \leq n-3$  and  $j \in \{1, m-1\}$  or  $i$  is even with  $4 \leq i \leq n-4$  and  $j \in \{1, m\}$ .

The only twist regions which are not allowable or almost allowable are the extreme right and left twist regions in rows 1, 2,  $n-2$  and  $n-3$ . These twist regions are called *extreme twist regions*.

**Corollary 4.6.** *If  $t'_{i,j} \in K'$  is an allowable or almost allowable twist region isolated by vertical 2-spheres  $S'_1$  and  $S'_2$ , then the bounded component of  $S^3 \setminus (\varphi(S'_1) \cup \varphi(S'_2))$  in  $(S^3, K)$  is a rational 2-tangle containing a single twist region  $t_{r,s}$ .  $\square$*

**Corollary 4.7.** *Let  $t'_{i,j}$  be an allowable twist region in  $K'$ . Then the allowable and almost allowable twist regions adjacent to  $t'_{i,j}$  in  $K'$  are mapped to twist regions adjacent to  $\varphi(t'_{i,j}) = t_{r,s}$  in  $(S^3, K)$  in the same order, up to rotation along a vertical axis through the  $t_{r,s}$  twist region.*

*Proof.* Let  $S'_1$  and  $S'_2$  be vertical 2-spheres that isolate  $t'_{i,j}$ . As in Corollary 4.6, the images  $\varphi(S'_1)$  and  $\varphi(S'_2)$  isolate the twist region  $t_{r,s}$  in  $K$ . Each allowable or almost allowable twist region adjacent to  $t'_{i,j}$  (at most four in the general case) shares a segment of  $K'$  with  $t'_{i,j}$ . This segment intersects only one of the vertical 2-spheres  $S'_1$  or  $S'_2$ , so it must be mapped to a segment meeting the image of the same vertical 2-sphere in  $(S^3, K)$ . Thus adjacent allowable and almost allowable twist regions are mapped to adjacent allowable and almost allowable twist regions. Twist regions are symmetric with respect to rotations in the vertical and horizontal axis. However the long bridge at the bottom of the braid prevents a rotation in the horizontal axis.  $\square$

**Lemma 4.8.** *If  $t'_{i,j}$  is an allowable or almost allowable twist region in  $(S^3, K')$  that is mapped to  $t_{r,s}$  in  $(S^3, K)$  then the number of crossings in the twist regions agree:  $a_{r,s} = a'_{i,j}$ .*

*Proof.* The proof is identical to that of [10, Lemma 4.11].  $\square$

In light of Lemma 4.8, it remains to check that the extreme twist regions are also fixed. Again the argument is just as the argument in the odd  $r$  case. First, we define isolating spheres for extreme twist regions. Let  $\gamma'$  be a curve encircling the top left twist regions  $t'_{1,1}$  and  $t'_{2,1}$ , as in Figure 7. Cap  $\gamma'$  by disks in front of and behind  $P$  to obtain a 2-sphere  $S'_\ell$  bounding the rational 2-tangle  $1/(a'_{1,1} + 1/a'_{2,1})$ . Similarly form  $S'_r$  in the top right.

**Lemma 4.9.** *The 2-sphere  $\varphi(S'_\ell)$  bounds a rational 2-tangle corresponding to the continued fraction expansion  $1/(a_{1,1} + 1/a_{2,1})$  (or  $1/(a_{1,m-1} + 1/a_{2,m})$ ). Thus, up to rotation,  $a_{1,1} = a'_{1,1}$  and  $a_{2,1} = a'_{2,1}$ . Similarly for the right corner.*

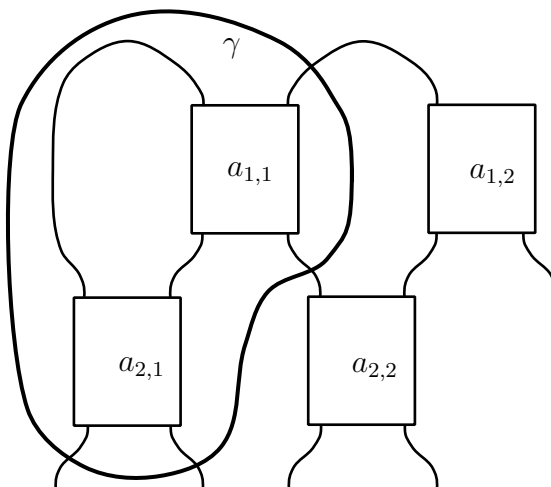

FIGURE 7. The  $\gamma$  curve for an isolating sphere for the extreme twist regions. Figure originally from [10].

*Proof.* Because a sub-arc of  $\gamma'$  lies on the vertical 2-sphere  $S'(1, \dots, 1)$ , the image  $\varphi(S'_\ell)$  shares a sub-disk with the vertical 2-sphere  $\varphi(S'(1, \dots, 1))$ . By Corollary 4.7, without loss of generality  $\varphi(S'(1, \dots, 1)) = S(1, \dots, 1)$ . Since points  $K \cap \varphi(S'_\ell)$  are fixed on  $S(1, \dots, 1)$ , it follows that  $\varphi(S'_\ell)$  is a sphere bounding the extreme tangle in the top left corner of  $K$ . Thus  $1/(a'_{1,1} + 1/a'_{2,1}) = 1/(a_{1,1} + 1/a_{2,1})$ . Then  $a_{1,1} = a'_{1,1}$  and  $a_{2,1} = a'_{2,1}$ , and similarly for the extreme twist regions in the right corner of the plat.  $\square$

**4.3. Proof of Theorem 1.1.** We have now assembled all the required pieces.

*Proof of Theorem 1.1.* Let  $\mathcal{K} \subset S^3$  be a knot or link with a  $2m'$  e-plat projection  $K'$ , where  $m' \geq 4$ ,  $K'$  is 3-highly twisted, and length  $n' > 4m'(m' - 2)$ . Assume further that  $\mathcal{K}$  has an additional  $2m$  plat projection or e-plat projection  $K$ . Then Theorem 2.7 implies  $m \geq m'$ . If  $m' = m$ , and  $K$  is 1-highly twisted, then Corollary 3.10 implies that the length  $n$  of  $K$  equals the length  $n'$ . So  $K$  is an e-plat projection.

It then follows from Corollary 4.6 through Lemma 4.9 that the twist regions in both plats are equal, namely  $t_{i,j} = t'_{i,j}$  up to rotation along a vertical axis, and  $t_{i,j}$  and  $t'_{i,j}$  contain the same number of (signed) crossings, i.e.  $a_{i,j} = a'_{i,j}$ . Thus up to rotation in a vertical axis,  $K = K'$  and the plat is unique.  $\square$

## REFERENCES

1. David Bachman and Saul Schleimer, *Distance and bridge position*, Pacific J. Math. **219** (2005), no. 2, 221–235.
2. Gerhard Burde and Heiner Zieschang, *Knots*, de Gruyter Studies in Mathematics, vol. 5, Walter de Gruyter & Co., Berlin, 1985.
3. Elizabeth Finkelstein and Yoav Moriah, *Tubed incompressible surfaces in knot and link complements*, Topology Appl. **96** (1999), no. 2, 153–170.
4. ———, *Closed incompressible surfaces in knot complements*, Trans. Amer. Math. Soc. **352** (2000), no. 2, 655–677.
5. David Futer, Efstratia Kalfagianni, and Jessica S. Purcell, *Dehn filling, volume, and the Jones polynomial*, J. Differential Geom. **78** (2008), no. 3, 429–464.

6. David Futer and Jessica S. Purcell, *Links with no exceptional surgeries*, Comment. Math. Helv. **82** (2007), no. 3, 629–664.
7. J. Johnson and Y. Moriah, *Bridge distance and plat presentations*, arXiv:1312.7093 [math.GT].
8. Jesse Johnson and Maggy Tomova, *Flipping bridge surfaces and bounds on the stable bridge number*, Algebr. Geom. Topol. **11** (2011), no. 4, 1987–2005.
9. Martin Lustig and Yoav Moriah, *Generalized Montesinos knots, tunnels and  $\mathcal{N}$ -torsion*, Math. Ann. **295** (1993), no. 1, 167–189.
10. Yoav Moriah and Jessica S. Purcell, *Uniqueness of diagrams of highly twisted plats*, 2017.
11. Horst Schubert, *Knoten mit zwei Brücken*, Math. Z. **65** (1956), 133–170.
12. Maggy Tomova, *Multiple bridge surfaces restrict knot distance*, Algebr. Geom. Topol. **7** (2007), 957–1006.
13. Ying-Qing Wu, *Incompressible surfaces in link complements*, Proc. Amer. Math. Soc. **129** (2001), no. 11, 3417–3423 (electronic).

DEPARTMENT OF MATHEMATICS, TECHNION, HAIFA, 32000 ISRAEL  
*E-mail address:* ymoriah@technion.ac.il

SCHOOL OF MATHEMATICAL SCIENCES, MONASH UNIVERSITY, VIC 3800 AUSTRALIA  
*E-mail address:* jessica.purcell@monash.edu